

PHB SERIES

EXTRA LARGE CAPACITY BOX BLADES

by **TUFLINE**

ASSEMBLY AND OPERATING INSTRUCTIONS

MONROE-TUFLINE MANUFACTURING CO., INC.
P.O. BOX 186 / 2219 TUFLINE LANE
COLUMBUS, MS 39703
PHONE (662)328-8347 / FAX (662)328-8361

INTRODUCTION

We are pleased that you have chosen a TUFLINE product. To assist you in the assembly and safe operation of your unit, we are providing this booklet. We urge you to read this booklet and thoroughly familiarize yourself with all aspects of safety, assembly, and operation. **Note:** All information contained in this booklet is general in nature and to be used for instructional purposes only. Actual appearance, material and specifications may vary somewhat depending on the specific model being assembled or adjusted.

All references made to the left or right in this booklet are determined by standing at the rear of the machine and facing the direction of travel.

** DISCLAIMER **

Any modifications to this product without the specific permission of TUFLINE are not allowed. Unauthorized modifications beyond the original factory specifications could cause damage to the unit and void the warranty.

** LIMITED WARRANTY **

Monroe Tufline Mfg. Co. Inc., the manufacturer, warrants only to the original purchaser of new TUFLINE equipment that they are free of defects in material and workmanship under normal use and service. This warranty is applicable for six months from date of purchase if for personal use; 90 days for commercial or rental purposes. This warranty does not apply to any equipment which has been improperly assembled or which has been subjected to abuse, negligence, normal wear and tear, modifications, tampering or failure to follow operating instructions, or which has been used for a purpose for which the product is not designed. This warranty does not cover any parts not manufactured by Monroe-Tufline Mfg., Inc.

Claims shall be made to the dealer who originally sold the equipment. Warranty coverage is not valid unless the owner registration card below is completed and returned. All claims must be submitted within 30 days of equipment failure and faulted parts or equipment are subject for return to TUFLINE at TUFLINE'S expense and discretion. Monroe-Tufline reserves the right to make improvements and/or changes in specifications of the product at any time without notice or obligation to modify previously manufactured unit.

No other warranty of any kind whatsoever, express or implied, is made with respect to this sale; and all implied warranties of merchantability and fitness for a particular purpose which exceed the obligations set forth in this written warranty are hereby disclaimed and excluded from this sale.





**Please fill out the registration card below and mail it to:
Monroe Tufline MFG. Attention: Owner Registration
P.O. Box 7755 Columbus, MS 39705**

OWNER REGISTRATION





Name _____ Address/City _____
State _____
Dealer Name _____ City/State _____
Date of Purchase _____ Model No. _____ Serial # _____
Comments _____

GENERAL SAFETY INSTRUCTIONS

HITCHING:



-  Before hitching always be certain that the proper hitch pins are available for each hitch position. Use of incorrect parts can allow an unexpected and possibly disastrous partial or complete disconnection from the tractor. This can result in serious property damage and/or personal injury.
-  It is very important to throttle the engine to idle speed as the tractor is backed up to the implement. Make sure that all helpers are clear.
-  Be sure the implement is solidly supported to prevent movement during hitching.
-  Never place hands or fingers in possible "pinch points" such as hitch pin holes.

TRANSPORTING:

-  Never allow anyone other than the operator to be on or around the tractor or implement when it is being operated or moved. No riders anywhere!
-  Use all of the required safety equipment such as slow moving vehicle signs, etc.
-  Obey all area traffic regulations. If the implement is over width, be courteous and pull off the road and stop to allow long lines of traffic to pass safely.
-  Never transport at night without proper front and rear caution lights.
-  Never transport at speeds in excess of 20 MPH on paved roads or highways.

-  On bumpy roads, be aware that implements cannot withstand severe bouncing. Bouncing can also cause the tractor to swerve and this can result in an accident.

OPERATION:

-  STOP the tractor engine and apply the the parking brake before leaving the tractor seat.
-  Always operate at reasonable field speeds. Absolute maximum for earth-moving implements is 7 MPH. Lower speeds are recommended if the terrain is uneven or obstructions such as rocks are present.
-  Use extra caution and slow speeds on steep slopes, near power lines, gullies, and tree limbs.

ADJUSTMENTS:

-  Lower the implement to the ground when performing adjustments or maintenance.

BOX SCRAPER SAFETY:

-  Operator vision is limited during back-filling. Take extra precautions and remember that often tractors operate faster in reverse.

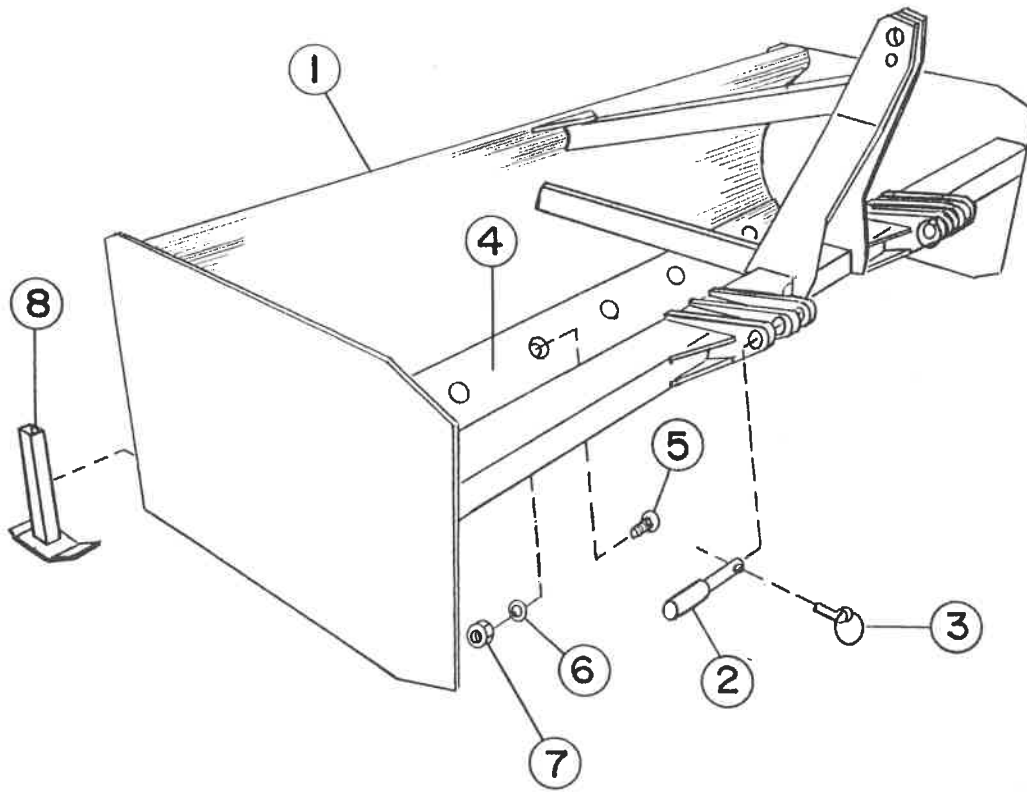

PHB- BOX SCRAPERS

REF. #	PART #	DESCRIPTION
1	13791	MAIN BOX FOR PHB-84
	13775	MAIN BOX FOR PHB-96
2	13257	HITCH PIN, CATEGORY 1 & 2
3	VP252	LYNCH PIN
4	10705	CUTTING EDGE, 1/2" X 6" X 84" FOR PHB-84
	10706	CUTTING EDGE, 1/2" X 6" X 96" FOR PHB-96
5	10699	PLOW BOLT, 5/8" X 1 1/2"
6	T-24	LOCK WASHER, 5/8"
7	T-22	HEX NUT, 5/8"
8	13772	SKID SHOE WELDMENT (OPTIONAL)

TROUBLE SHOOTING

PROBLEM

Box scraper is hard to control. Digs in and jumps out.

SOLUTION

Pitch or cutting angle is too steep. Flatten pitch by lengthening the top link if going forward or by shortening if going backward. Ground speed may be too great.

SAFETY DECAL PLACEMENT

****NOTE:** If safety decals have been damaged, removed, or become illegible, new decals must be applied. New decals are available from your distributor or dealer parts department or the factory.

